

## Rotary Cutter

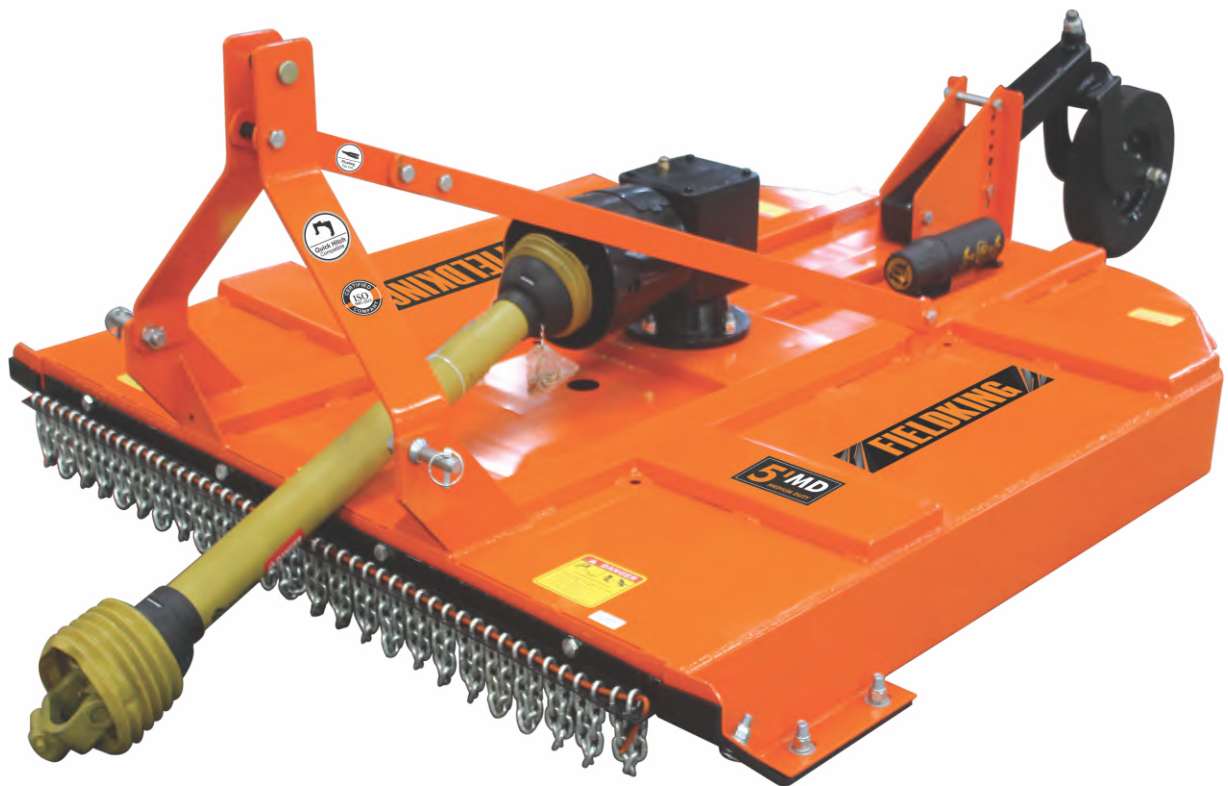

## CONGRATULATIONS!

You have invested in one of the best implements of its type in the market today.

The care you give your “FIELDKING USA” implement will greatly determine your satisfaction with its performance and its service life. A careful study of this manual will give you a thorough understanding of your new implement before operating.

If your manual is lost or destroyed, “FIELDKING USA” will be glad to provide you a new copy. Visit to nearest dealership & get a copy. Most of our manuals can also be downloaded from our website at [www.fieldkingusa.com](http://www.fieldkingusa.com).

As an authorized “FIELDKING USA” dealer, we stock genuine “FIELDKING USA” parts which are manufactured with the same precision and skill as our original equipment. Our trained service persons are well informed on methods required to service “FIELDKING USA” equipments and are ready to help you.

Should you require additional information or assistance, please contact us.

YOUR AUTHORIZED  
FIELDKING USA DEALER

BECAUSE “FIELDKING USA” MAINTAINS AN ONGOING PROGRAMME OF PRODUCT IMPROVEMENT, WE RESERVE THE RIGHT TO MAKE IMPROVEMENTS IN DESIGN OR CHANGE IN SPECIFICATION WITHOUT INCURRING ANY OBLIGATION TO INSTALL THEM ON UNITS PREVIOUSLY SOLD. BECAUSE OF THE POSSIBILITY THAT SOME PHOTOGRAPHS IN THIS MANUAL WERE TAKEN OF PROTOTYPE MODELS, PRODUCTION MODELS MAY VARY IN SOME DETAIL. IN ADDITION, SOME PHOTOGRAPHS MAY SHOW SHIELDS REMOVED FOR THE PURPOSE OF CLARITY. NEVER OPERATE THIS IMPLEMENT WITHOUT ALL SHIELDS IN PLACE.

## TO THE PURCHASER

This manual contains valuable information about your new "FIELDKING USA" Rotary Cutter. It has been carefully prepared to give you helpful suggestions for operating, adjusting, servicing and ordering spare parts.

Keep this manual in a convenient place for quick and easy reference. Study it carefully. You have purchased a dependable and sturdy Rotary Cutter but only by proper care and operation you can expect to receive the service and long life designed and built into it.

Sometime in the future your Rotary Cutter may need new parts to replace which are worn out or broken. If so, go to your dealer and provide him equipment's detail like model and part number.

### CUSTOMER INFORMATION

Name \_\_\_\_\_

Purchased From \_\_\_\_\_

Date of Purchase \_\_\_\_\_

Model No. \_\_\_\_\_

Serial No. \_\_\_\_\_

## **PURCHASER / OPERATOR'S RESPONSIBILITY**

1. Read and understand the information contained in this manual.
2. Operate, lubricate, assemble and maintain the equipment in accordance with all instructions and safety procedures in this manual.
3. Inspect the equipment and replace or repair any parts that are damaged or worn out which under continued operation would cause damage, wear to other parts, or cause a safety hazard.
4. Return the equipment or parts to the authorized "FIELDKING USA" dealer, from where it was purchased, for service or replacement of defective parts that are covered by warranty. (The "FIELDKING USA" Factory may inspect equipment or parts before warranty claims are honored.)
5. All costs incurred by the dealer for traveling to or transporting the equipment for warranty inspection and claims will be borne by the customer.

# INDEX

## **1. TECHNICAL DATA**

- 1.1 Introduction
- 1.2 Warranty
- 1.3 When The Warranty Becomes Void

## **2. USAGE INSTRUCTIONS**

- 2.1 Before Use
- 2.2 Setup Instructions
- 2.3 Running & operation instructions
- 2.4 Service Instruction
- 2.5 Installation Procedure
- 2.6 Adjustments
- 2.7 Safety & Equipment Safety Guideline
- 2.8 Safety Sign / Symbols & Location

## **3. MAINTENANCE & LUBRICATION**

- 3.1 Maintenance Instructions
- 3.2 Maintenance & Lubrication Scheduled
- 3.2 Storage, Removal & Disposal
- 3.4 Trouble Shooting Chart

## **4. PICTURE & PART CATALOGUE**

## 1. TECHNICAL DATA

### 1.1 INTRODUCTION

#### ROTARY CUTTER

The grass cutter mower horizontal cutting is the most versatile method of grass cutting. Rotary cutter is powerful enough to cope with tall weeds and small bushes, yet giving a satisfactory fine cut on turf areas mounted with optional front and rear rollers, scalping is minimal. Tractor-mounted rotary cutter, grass cutter provides a very cost-effective grass cutting solution. "FIELDKING USA" rotary cutter is one of the best machines in itself for cutting unwanted wild grass.

#### FEATURES

1. Designed for fast application to any type of 40-90 HP tractors with three point linkage.
2. Safety chain shield standard.
3. Tractor driven suitable for P.T.O. 540 R.P.M.
4. Rotary Cutter and grass cutting having steel blades for cutting wild grass, shrubs, weeds & etc.
5. Cutting width: approx. 4, 5, 6, 7 feet
6. Height adjustment: 2"~8" (50 ~ 200 mm)

#### Using This Manual

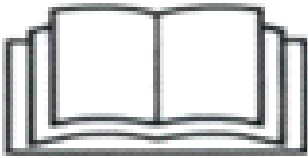

It is important that you thoroughly read and understand this manual before operation of the machine. You should also familiarize yourself with all aspects of operation, maintenance, trouble shooting and first and foremost safety.

#### Machine Description,

The cutting is a power take off (PTO) driven rotary machine designed to be attached to a tractor. The cutting blades are driven via one gearbox mounted to the cutter body.

#### The Purpose

This machine is designed and manufactured solely for the purpose of cutting grass and cover crops. Under no circumstances should it be used for any other purpose.

#### The Application and Limitations

The cutter's main application is the cutting of grass and cover crops on roadsides, ovals and paddocks. It is not recommended that it be used during wet or slippery conditions, or during poor visibility.

## Safety Training

- Safety is a primary concern in the design and manufacture of our product. Unfortunately, our efforts to provide safe equipment can be wiped out by a single careless act of an operator or bystander.
- In addition to the design and configuration of equipment, hazard control and accident prevention are dependent upon the awareness, concern, precaution and proper training of persons involved in the operation, transport, maintenance and storage of this equipment.
- It has been said, “The best safety device is an informed, careful operator.” We ask you to be that kind of operator. It is the operator’s responsibility to read and understand all safety and operating instructions in the manual and to follow them. Accidents can be avoided.
- Working with unfamiliar equipment can lead to careless injuries. Read this manual and the manual for your tractor, before assembly or operating, to acquaint yourself with the machines. If this machine is used by any person other than you, or is loaned or rented, it is the rotary mower owner’s responsibility to make certain that owner’s manual be available to the operator prior to operating:
  - Reads and understands the operator’s manuals.
  - Is instructed in safe and proper use.
- Know your controls and how to stop tractor, engine, and the mower quickly in an emergency. Read this manual and the one provided with your tractor.
- Train all new persons and review instructions frequently with existing workers. Be certain only a properly trained and physically able person will operate the machinery. A person who has not read and understood all operating and safety instructions is not qualified to operate the machine. An untrained operator ex-poses himself and bystanders to possible serious injury or death. If the elderly are assisting with farm work, their physical limitations need to be recognized and accommodated.

### 1.2 WARRANTY

When the implement is delivered, check that it has not been subjected to damage during transport and that the accessories are in a perfect condition and complete.

Any claims following the receipt of damaged goods shall be presented in writing within 8 days from the receipt of the goods.

The purchaser may only make the claims under warranty. When he has complied with the warranty conditions in the supply contract.

### 1.3 WHEN THE WARRANTY BECOMES VOID











Besides the cases specified in the supply agreement, the warrantee shall in any case become void:

1. When the implement has been used beyond the specified power limit like (Tractor Horse Power)
2. When repairs made by the customer without authorization from the manufacturer or owing to installation of spurious spare parts, the machine is subjected to variations and the damage can be ascribed to these variations.

3. When the user has failed to comply with the instructions in this handbook.
4. No warranty will be given if the service and greasing is not done on time.

## 2. USAGE INSTRUCTIONS

### 2.1 Before Using The Machine / Implement For The First Time !

-  **READ THE INSTRUCTION BOOK THOROUGHLY** before attempting to operate or carry out any maintenance on the machine. If you do not understand any part of this manual, ask your dealer for assistance.
-  **ALWAYS CARRY OUT SAFE MAINTENANCE.** Never clean, adjust or maintain the machine until the engine has been stopped, the machine come to rest, the PTO disengaged and the key removed.
-  **NEVER WORK UNDER A MACHINE RAISED ON THE 3-POINT LINKAGE** unless it is securely supported.
-  **NEVER OPERATE THE MACHINE WITH ANY PARTS OR GUARDS MISSING.** Check that all guards including the PTO shaft guards are in good condition and in place before operating the machine.
-  **OPERATE SAFELY.** Before starting work, check that there are no persons or animals in the immediate vicinity of the machine or tractor. Always maintain full control of the tractor and machine. Ensure that you know how to stop the tractor and machine quickly in case of emergency.
-  **SECURE THE PTO GUARD BY MEANS OF CHECK CHAINS** to suitable points on the tractor and machine to prevent the outer plastic shield from rotating.
-  **NEVER STAND BETWEEN THE MACHINE/IMPLEMENT AND THE TRACTOR WHEELS.**
-  **DO NOT WEAR LOOSE OR RAGGED CLOTHING**
-  **BEWARE OF DUST.** Under dusty conditions, keep the cab windows and doors closed. The use of a dust mask conforming to EN149 is strongly recommended.
-  **BEWARE OF HIGH NOISE LEVELS.** Some tractor/implement combinations give noise levels in excess of 90dB at the operator's ear. Under such circumstances, ear defenders should be worn. Keep cab windows and doors closed to reduce noise level. Throughout this handbook, the term 'tractor' is used to refer to the power source used to drive them machine. It does not necessarily refer to a conventional agricultural tractor.

### 2.2 Setup Instructions

Connecting to tractor and setting up adjustments

#### I.) Three point linkage units

1. Locate the cutter on a flat, level surface.



2. Determine the category pin size to suit the tractor: Cat. 1 : Bottom link 7/8" top link 3/4" & Cat. 2 : Bottom link 11/8" top link 1"
3. Carefully reverse the tractor and line up the lower link pins.
4. Engage the park brake, shut off the tractor and remove key before dismounting the tractor.
5. Fit the correct size pins and secure with linch pins.
6. Adjust the top link so that it fits between tractor and cutter. Slotted top link will enable 60mm of float to reduce skids ploughing.
7. Adjust the sway bars/chains to hold the cutter central to the tractor and prevent the cutter from swinging sideways.
8. To fit the Power Take Off (PTO) shaft to the cutter and tractor, press the quick disconnect pin and simultaneously slide the female spline onto the male spline until the pin engages.
9. Check that the locks are securely engaged after coupling.
10. Start the tractor and slowly engage the tractor's hydraulic 3 point linkage to lift the cutter.
11. Check for sufficient draw bar clearance and adjust as required.
12. Watch the telescoping movement of the shaft to ensure that it does not bottom out while lifting the 3 point linkage. If it does, refer to the link adjustment.
13. Raise the cutter to check that the PTO shaft does not contact the front of the cutter. Lock out the hydraulic lift so the lift cannot touch the shaft.
14. Measure the distance between the tractor PTO shaft and the clutch input shaft. The overall length of the PTO drive shaft should be approximately 50 mm less than the distance between the tractor PTO and the clutch shaft when the PTO is in the closed position, but still must be checked when fitted, to ensure the shaft does not bottom out and has an adequate amount of shaft insertion when in the extended position.
15. Fit the Power Take Off shaft to the cutter. Secure the other end to the tractor shaft, making sure the clips are secure in the shaft grooves.
16. Raise the cutter to make sure the drive shaft does not foul on the front body. If it appears to come close to touching, raise the cutter to give a safe clearance and lock the linkage stop to prevent it fouling.
17. Never raise the cutter higher than necessary when turning or moving from one area to another.
18. Always lower the cutter gently to the ground, adjusting the drop rate on tractor hydraulics if necessary.

## ii.) **Cutters with skids only**

1. Adjust the top link to bring the front of the cutter skids clear of the ground by approximately 15mm.

**iii.) Slashers with roller or wheels at rear**

1. Adjust the top link to the cutting height required. The adjustment on the roller or wheels may be used to level the slasher if desired.

**2.3 RUNNING & OPERATION INSTRUCTIONS**

1. Always disengage the tractor's PTO before lifting the slasher to transport position.
2. When raising the cutter to the transport position check that the driveshaft does not contact the tractor or slasher, refer back to setup instructions if contact occurs.
3. Leave enough clearance so the slasher does not come into contact with obstacles or ground.
4. Limit transportation speed to 20Km/h. When travelling on roadways do so in a manner that allows faster vehicles to pass safely. Be sure to reduce tractor speed when turning.
5. In addition to design, accident prevention and hazard control are dependent on awareness, concentration, correct training and an attentive operator. Before beginning to cut, the following inspection checklist should be performed.

**Instructions for operation**

1. Lower the slasher down on a clear, level area to check the set up.
2. Set the hand brake on and set the tractor gears to neutral.
3. Select the correct Power Take Off (PTO.) speed and set the tractor rpm. to just above idle.
4. Slowly engage the PTO, do not use full throttle. The slasher is equipped with swing back blades to reduce shock loads if the slasher strikes an obstacle. Allow 10 seconds for the blades to align themselves and when the slasher is running smoothly, increase the PTO speed to the required speed.
5. Ground speed is determined by three things:
  - The density of the material being cut
  - The difficulty of the terrain
  - The size of the tractor
6. Never run the slasher through material at speeds that will cause the tractor to overload.
7. When slashing on sloping surfaces, operate at a reduced speed to ensure that the risk of loss of control or tractor rollover is minimized.
8. It is important to retain the correct PTO speed (540 rpm unless specified), less of PTO speed will allow blades to hinge back and may result in an uneven or ragged cut.
9. Slow down when changing direction or coming in and out of rows. If necessary turn off PTO and lift unit to stop dragging while turning.

10. These instructions are a guide only and should be read in conjunction with the tractor manual and with safety instructions given by qualified training instructors.

## **2.4 SERVICE INSTRUCTION**

### **1. General**

1. It is dangerous to use the PTO drive shaft without guard and the restraining members correctly attached. A drive shaft guard restraining system is required in most areas. If you are unsure, check local regulations.
2. Do not expose guarded parts of the shaft by cutting or enlarging the grease access holes.
3. Do not step on or over a drive shaft.
4. PTO drive shafts and (safety) clutches have to match the power take off of the machine type. See the instructions with your machine for recommended type and size of shaft and clutches. Overloading can cause damage.
5. Do not operate above recommended speeds.
6. It is against regulations to connect clutches to the tractor PTO in most areas. If you are unsure, check local regulations.
7. No device (e.g. adaptors) shall be installed between the tractor PTO and the PTO drive shaft.
8. No changes except length adjustment may be made to the PTO drive shaft and its guard.
9. Do not operate without all drive line guards, tractor and equipment shield in place. Drive lines must be securely attached at both ends and drive line guards must turn freely on drive line.

### **2. Restraining Members**

1. A drive shaft guard restraining system is required in most areas. If a chain is the method of restraining the drive shaft guard, the following must be taken into account.
2. Chains must be securely attached to the master shield of the tractor and the guard on the implement, in order to prevent the guard from rotating. Be careful to allow sufficient movement of the shaft in all working and transport positions.
3. Damaged chains need to be replaced immediately. Never use the chain to support the PTO drive shaft. If the PTO shaft is uncoupled from the tractor PTO, or self propelled machine, always connect the shaft to the support point of the implement.

## **2.5 INSTALLATION PROCEDURE.**

### **TRACTOR REQUIREMENTS**

Ensure the specifications of the tractor meet the requirements listed below:

- 6 spline PTO of 1.3/8" dia.
- PTO output of 540 rev/min.
- Category I & II - 3point linkage.

## PREPARING THE TRACTOR

- Remove any brackets or objects which may obstruct operation of lift arms.
- Disengage PTO drive and expose PTO drive shaft.

## PREPARING THE MACHINE

The machine will normally be delivered fully assembled.

For export markets the rotary cutter may require minor assembly to change from the machines transport state to the machines working state.

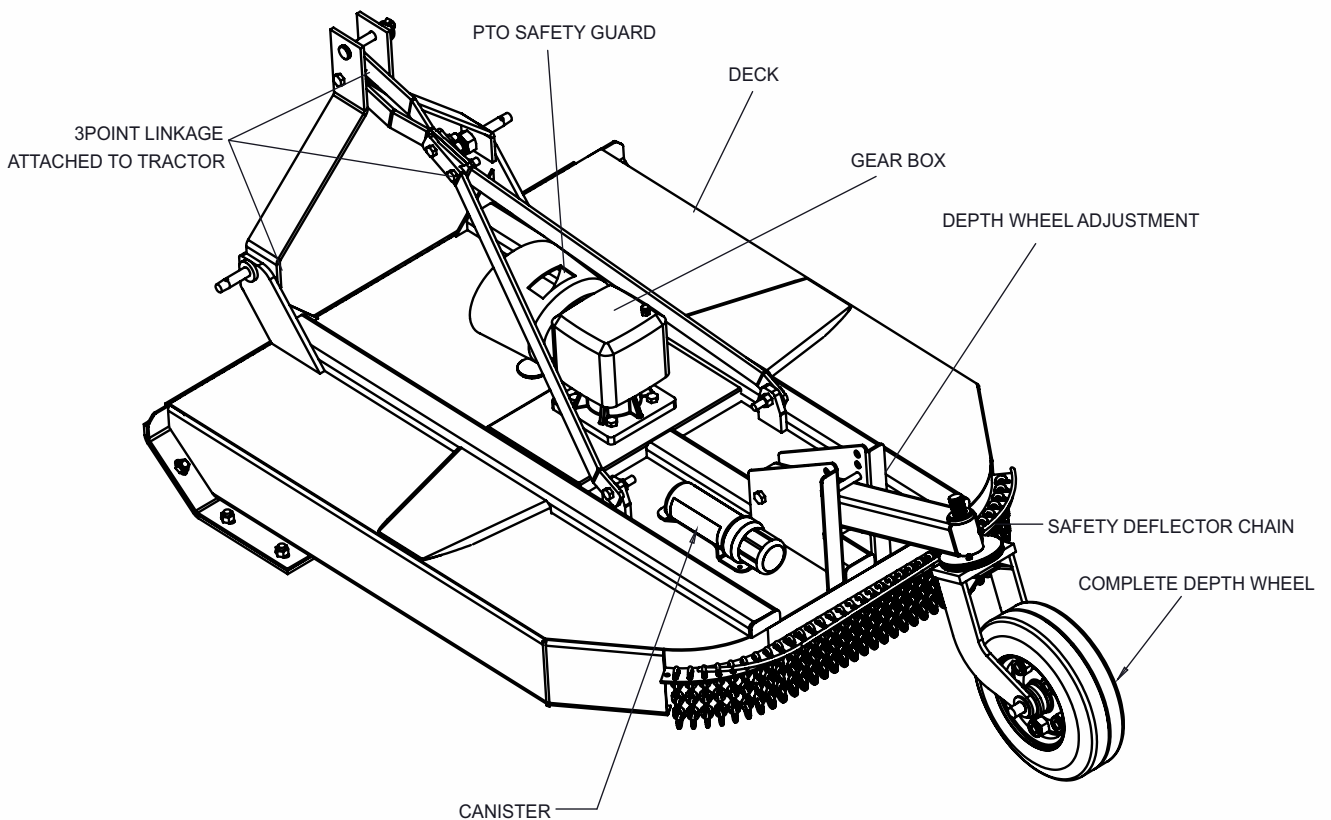

## ROTARY CUTTER



## **PTO SHAFT WITH SLIP CLUTCH**

- Unbolt the wheel beam from the two transport brackets securing the wheel beam to the deck.
- Assemble the wheel beam in its working position on the deck by fastening bolt to bracket on the deck.
- Fasten nut and bolt into wheel beam assembly location.
- Unfasten cable ties holding lower links arms in place, positions and secure lower links in place using lower link pins in positions.
- Ensure all fasteners are securely tightened. The machine is then in its working position.

## **FITTING MACHINE/IMPLEMENT TO TRACTOR**

To fit the machine to the tractor the following instructions must be adhered to:

- Disengage PTO drive.
- Reverse tractor squarely to the machine.
- Gradually reverse tractor until lift arm Holes are level with mounting pins.
- Fit left lift arm into mounting pin.
- Adjust height of right lift arm if necessary.
- Fit right arm on to the mounting pin then lock with lynch pin.
- Fit top stay of machine to top link on Tractor , adjusting the length with the machine level on the skids
- Secure with pins provided with tractor.
- Adjust lift arm check chains to prevent machine from swaying when raised.

## **FITTING PTO**

Due to many different makes and sizes of tractor to which FIELDKING USA Rotary Cutter/Lawn Mower can be fitted, a nominal length of PTO shaft is supplied with the machines. In some cases it may be found that this PTO shaft is too long and will have to be shortened.

## **IMPORTANT**

MINIMUM ENGAGEMENT OF PTO SQUARE DRIVE IS 100MM (4IN) AND 150MM (6IN) FOR THE LEMON TUBE TYPE IN WORKING POSITION THIS MEASUREMENT MUST BE TAKEN INTO ACCOUNT WHEN SHORTENING THE PTO SHAFT.

- Remove Burrs
- Before fitting PTO shaft to tractor, grease the sliding drive shafts and bearing units.
- Fit PTO to tractor ensuring locking peg on the splined coupling is full engaged.
- Attach PTO guard check chains to tractor and machine.
- Both machinery and tractor must be parallel to one another.

## 2.6 ADJUSTMENTS



### CLUTCH SETTING

The friction plate clutch is to be set such that it will not slip in normal working conditions, but will slip should any significant obstacle be struck. The initial clutch setting given is a guide only and may need to be varied, depending on local conditions. NOTE: DURING INITIAL USE, CHECK CLUTCH REGULARLY FOR OVERHEATING OF THE CLUTCH. The clutch will 'bed in' and require re-setting after a short period of use. Failure to do this may result in excessive wear of the clutch components - see UNDER-TIGHTENING.

UNDER-TIGHTENING of the clutch springs will cause unnecessary slippage of the clutch which will result in excessive wear of plates and eventually complete failure of clutch components due to overheating. In normal obstacle free operation the clutch should be no hotter than the gearbox. If the clutch overheats, increase clutch spring compression by 1/4 turn on each nut and re-check clutch temperature after a short period of work and re-adjust if necessary. [Note: In light conditions it may be necessary to continue working for 15-30 minutes to determine if clutch setting is suitable, however in heavy conditions 25 meters of distance should be sufficient work to check clutch setting. WARNING - Do not over-tighten clutch.

**OVER-TIGHTENING** of the clutch springs will not allow the clutch to function correctly, possibly resulting in torque induced shear failure of drive line components, should an obstacle be encountered.

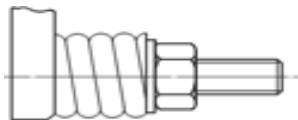
### INITIAL CLUTCH SETTING

	<p>Tighten nuts to coil bind springs then back off nuts as shown below.</p>
	<p>If clutch overheats in normal operation tighten each nut 1/4 turn and re-check after further work. Re-adjust if necessary</p>
<p>NOTE: Failures of UNIVERSAL DRIVE-SHAFT, CLUTCH, or GEARBOX that are attributable to incorrect clutch setting, are not covered by warranty.</p>	

### ADJUSTING CLUTCH SETTING TO SUIT WORKING CONDITIONS

The recommended procedure to 'fine tune' the clutch setting to suit the tractor and working conditions is as follows:

- I. Set the clutch to the recommended initial setting – err on the low side.

- ii. Work the rotary cutter in normal to heavy conditions for 10 – 20 meters.
- iii. Shut down tractor and wait until the PTO stops turning, then get off tractor and check the clutch temperature.
- iv. If it is heating up due to slippage, tighten adjusting nuts  $\frac{1}{4}$  turn.
- v. Repeat steps ii – iv until no further heating occurs.

SEIZURE of the clutch can be caused by rusting of the steel clutch plate facings due to atmospheric moisture and/or rain. Seizure of the clutch may cause it to function incorrectly, possibly resulting in torque induced shear failure of drive line components, should an obstacle be struck. To prevent this occurring it is necessary to periodically 'free the clutch' and ensure that it slips, then reset it. To 'free the clutch' follow steps below:

- i. Slacken off the clutch springs until compression in springs is almost nil.
- ii. Connect the cutter to the tractor and engage the PTO drive and ensure clutch spins freely (does not drive the blade beam). This will also polish any rust from clutch plate facings.

**WARNING!** Refer to SAFETY PRECAUTIONS in relation to performing this maintenance work.

- iii. If the clutch will not disengage it may be necessary to remove it from the CUTTER and clean or repair as required.
- iv. Reset clutch.

**CUTTING HEIGHT – When close to persons or traffic it is strongly recommended the ROTARY CUTTER is adjusted to 100mm minimum cut height.**

If working within 300m of persons or passing traffic (in particular, this includes maintenance of vacant suburban blocks and roadsides) be aware that debris buried within the grass can be picked up and thrown. Debris such as lengths of steel (pipe, posts or star pickets) or lengths of timber can become lethal projectiles. The recommended minimum cut height in these areas is 100mm (nominal cut height on flat ground.) The higher cut height will lower the possibility of the blades scalping and throwing debris, however prior to beginning work, a thorough inspection of the whole area to be cut is strongly recommended.

Vacant suburban blocks can be particularly dangerous due to the following:

- a. They are often a dumping ground for rubbish (debris).
- b. They are often left uncut for long periods, then an extremely low cut is requested to avoid more frequent maintenance.
- c. They are typically subject to both passing traffic and nearby persons (neighbours or passing pedestrians).
- d. Complete and rigorous checking of the whole area to be cut is time consuming and even then may not reveal dumped debris, especially if it is partially buried.

## **CUTTING HEIGHT – BLADE CLEARANCE**

Adjust the rotary cutter depth wheel and tractor three-point linkage so that the required cutting height is achieved. The following 2 points should however be considered:

- I. FORWARD CUTTING for predominantly forward cutting the blades should cut 1-2cm lower at the front of the cutter than the rear. This will prevent blades back cutting, reduce blade wear and 'dust' and lower the power required.
- ii. FORWARD & REAR CUTTING It is advisable to adjust the linkage and cutter so that the blade beam is cutting horizontally.

## CUTTING HEIGHT - ADJUSTMENT WHEN USING WHEELS

On level ground adjust the rotary cutter height control wheels and tractor lower linkage arms to give the required cutting height taking into account points i & ii above. Then extend the three-point linkage top link such that there is sufficient slack in the rotary cutter chain backstays to allow the rotary cutter to follow the ground contours. Adjust the skids to give suitable clearance between the underside of the skid and the ground. (Typical clearances are: front - 5-7mm, rear - 10 mm. Excessive clearances will allow potentially dangerous ejection of material from under the rotary cutter.)

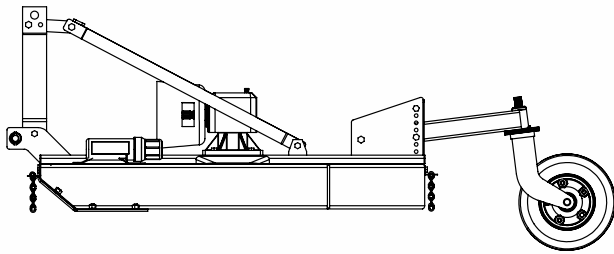

Fig. 1

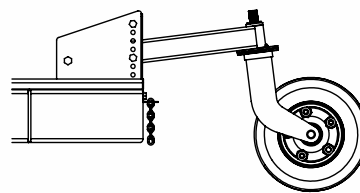

Fig. 2

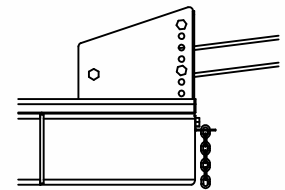

Fig. 3

## 2.7 SAFETY & EQUIPMENT SAFETY GUIDELINE

### HEALTH AND SAFETY AT WORK!

Our equipment is designed so as to conform to current Health & Safety Regulations and therefore poses no significant hazard to health when properly used. Nevertheless, in the interests of all concerned, it is essential that equipment of our manufacture is used in accordance with the instructions that are supplied or are available from our Technical Staff.



Legislation requires that all operators are instructed in the safe operation, cleaning and maintenance of equipment and machines. This handbook forms part of that instruction and it must be read and understood before fitting the machine onto the tractor or attempting to use it.

Your supplier is responsible for carrying out any necessary pre-delivery inspection, fitting the machine onto the tractor and test running. The supplier must also give instruction in the safe use, maintenance and adjustment of the machine.

In the interests of safety, please ensure that the instructions referred to above are brought to the attention of all your employees who are to use the equipment. We recommend that the use of this equipment is restricted to capable trained operatives. Persons under the age of sixteen should not operate the machine and should be kept away from where it is being used.



## Safety Instructions

Sequence of Job steps	Potential Hazard of each step	Standard Operating Procedure	Personal Protective Equipment
Special note.		No persons are to use this equipment prior to; Reading and understanding the operators manual. Reading the standard operating procedure. Undergoing thorough practical training while properly supervised.	
Pre-start maintenance checks.	<i>Flying machine parts Severe bodily injury.</i>	Ensure the cutter is checked prior to use and is in good working condition .	<b>Overalls safety Boots, gloves.</b>
Special note.	<i>Flying debris.</i>	Where the tractor being used does not have an enclosed cab or other protective material should be fitted to stop flying debris hitting the operator.	
Start up machine.	<i>Flying machine parts Severe bodily injury.</i>	As an added safety precaution, when visual assessment of the machine has been completed, perform a test run prior to commencing field operations. Engage the PTO and check the cutter from the tractor cab If all ok, disengage PTO prior to travelling to the job site.	<b>Eye protection, Overalls High visibility , Safety Vest, Safety boots.</b>
Travelling to job site.	<i>Accident, Damage off course, Tip over, Risk of being crushed.</i>	Ensure the cutter is at maximum height when travelling at road speed as the CUTTER could strike the road or other objects and cause the tractor to damage off course. Periodically check that the cutter is still at maximum height.	<b>Eye protection, Overalls High visibility , Safety Vest, Safety boots.</b>
Commence slashing operation.	<i>Flying debris, Eye injury, Bodily injury, Tip over, Risk of being crushed, Cuts , Hearing damage.</i>	Clear the entire area of any people before commencing slashing. Survey the area to be slashed. Check the slope of the land, if applicable. Clear the area to be slashed of any obvious hazards, e.g. large stones, large Branches (twigs) from trees, wire etc. Select the correct height adjustment for the cutter for the task at hand. If wire or other objects become caught in the blades, apply the brakes to tractor and switch off the Engine. When the cutter is lifted to remove objects from the blade, it must be supported by safety stands or the equivalent.	<b>Eye protection, Overalls High visibility , Safety Vest, Safety boots , Gloves, Hearing protection.</b>
Special note.		Thoroughly check the cutter every 2 hours, tractor gear must be in neutral, the Engine switched off and PTO disengaged.	
Finish cutting operation.	<i>Accident. Damage off course. Tip over. Risk of being crushed.</i>	When returning to the storage shed, ensure the cutter is at maximum height When travelling at road speed as the cutter could strike the road or other objects causing the tractor to Damage off course. Periodically check that the cutter is still at maximum height.	<b>Eye protection, Overalls High visibility , Safety Vest, Safety boots.</b>
Clean up.	<i>Cuts and Damages, Burns. Slipping.</i>	Thoroughly check the equipment for any damage. Report any equipment damage to the manager. Place safety tag (danger- do not operate) on the equipment until repaired, indicating faults on tag. Once the equipment is repair, tag is not to be removed or equipment operated until sanctioned by appointed safety officer and/or manager. On completion of repairs and service, clean the cutter thoroughly (with high pressure cleaner if available), ensuring proper care is taken and the correct protective clothing/equipment is being worn.	<b>Eye protection, Face sheild. Overalls. Safety boots. Gloves.</b>

Indicates a potentially hazardous situation which, if not avoided, could result in death or serious injury, and includes hazards that are exposed when guards are removed. It may also be used to alert against unsafe practices. Indicates a potentially hazardous situation which, if not avoided, may result in minor or moderate injury. It may also be used to alert against unsafe practices.

### **Carefully follow the instructions given on the Symbols.**

1. Driveline Missing - Ensure PTO guard is fitted to the machine before operating.
2. Read Instructions - Always fully read and understand the instructions before using the machine.
3. Keep Nuts Tight - Ensure all nuts are tight before commencing work with the machine.
4. Keep Out Zone - Keep at a safe distance from the machine to avoid being crushed.
5. Unsupported Machine - Do not attempt to get underneath the machine because of the risk of fall.
6. Thrown Debris - Keep at a safety distance from the machine to avoid the risk of debris being thrown from the machine.
7. Rotary Head Danger - Remove the ignition key and read the instructions before working on or getting close to the machine, as the blades may still be rotating.
8. Shaft Entanglement - Keep at a safe distance from the machine to avoid being caught in guarding, rotor shaft, or the PTO shaft.
9. Unblock Rotary Blade – Ensure rotary Blade has come to a complete stop before attempting to unblock these blades.
10. Max PTO Speed 540 ACW – PTO speed not to exceed 540 RPM anti-clockwise.
11. Safety of the operator and bystanders is one of the main concerns in designing and developing a cutter. However, every year accidents occur which could have been avoided by a few seconds of thought and a more careful approach to handling equipment. You, the operator, can avoid many accidents by adopting the following precautions and insist those working with you, or for you, follow them.
12. In order to provide a better view, certain photographs or illustrations in this manual may show an assembly with a safety shield removed. However, equipment should never be operated in this condition. Keep all shields in place. If shield removal becomes necessary for repairs, replace the shield prior to use.
13. Replace any safety sign that is not readable or is missing. Copies of such safety signs are shown in this manual.

14. Never use alcoholic beverages or drugs that can hinder alertness or coordination while operating this equipment. Consult your doctor about operating this machine while taking prescribed medications.
15. Under no circumstances should children under the age of 18 be allowed to work with this equipment. Do not allow persons to operate or assemble this unit until they have read this manual and have developed a thorough understanding of the safety precautions and of how it works. Review the safety instructions with all users annually.
16. This equipment is dangerous to children and persons unfamiliar with its operation. The operator should be a responsible, properly trained and physically able person familiar with farm machinery and trained in this equipment's operations. If the elderly are assisting with farm work, their physical limitations need to be recognized and accommodated.
17. Use a tractor equipped with a Roll over Protective System and seat belts. (ROPS)
18. Never exceed the limits of a piece of machinery. If its ability to do a job, or to do so safely, is in question- DON'T TRY IT.
19. Do not modify the equipment in any way. Unauthorized modification could result in serious injury or death of operator or may impair the function and life of the equipment.
20. In addition to the design and the configuration of this implement, including safety signs and safety equipment, hazard control and accident prevention are dependent upon the awareness, concern, precaution, and proper training of persons involved in the operation, transport, maintenance and storage of the machine. Also Refer to safety messages and operating instruction in each of the appropriate sections of the tractor and rotary cutter manuals. pay close attention to the safety signs affixed to the tractor and the rotary cutter
21. NEVER place hands or feet under the rotary cutter, or Endeavour to make any repairs or adjustments, while the blades are rotating; this equipment is capable of inflicting serious injury.
22. NEVER touch the blades or attempt to free any obstacle jammed by the blade beam while the tractor engine is running. The clutch may be slipping and removal of any obstruction may allow the blades to suddenly begin rotating with serious injuries being a very real possibility. Ensure that the engine has been shut off, the PTO disengaged, the tractor key removed and blades are not rotating.



## PRE-OPERATIONAL SAFETY CHECKS

- Operate only with roll over protection structure (ROPS) and seatbelt equipped tractors.
- Ensure that all guards are fitted, secure and functional.
- Ensure that the 3-point linkage, PTO shaft and safety chains are in sound condition.
- Ensure that the blades and fasteners are in sound condition.
- Ensure that hydraulic rams, hoses and couplings of tractor are in sound condition.
- Ensure that the rotary cutter is attached according to manufacturer's specification.
- Faulty equipment must not be used. Report suspect machinery immediately.

## OPERATIONAL SAFETY CHECKS

- Keep clear of moving machine parts.
- Allow no passengers on tractor or rotary cutter.
- Do not use rotary cutter with bystanders in area.
- Be sure the transmission is out of gear and the PTO should be disengaged before starting the engine.
- Allow moving parts on rotary cutter to stop before repair.
- Securely support the mower before working underneath. Chock tractor wheels.
- Lock up raised levers (where fitted) before transport.
- Do not operate with raised levers (where fitted) in raised or transport position.
- Before dismounting the tractor: lower rotary cutter to ground and allow moving parts to stop.
- Stop engine and set brake.
- Remove key of unattended equipment.

## 2.8 SAFETY SIGN / SYMBOLS & LOCATION

Safety symbols are located on various points of the machine. They can be identified by the yellow upper panel depicting the hazard, and the lower white panel indicating means of avoidance or precautions to be taken. These Symbols have no text. It is essential that all operators and persons associated with the machine fully understand their meanings, which are shown below. Any safety Symbols which are found missing should be replaced. Carefully follow the instructions given on the Symbols.

### Look For The Safety Alert Symbol

The SAFETY ALERT SYMBOL indicates there is a potential hazard to personal safety involved and extra safety precaution must be taken. When you see this symbol, be alert and carefully read the message that follows it. In addition to design and configuration of equipment, hazard control and accident prevention are dependent upon the awareness, concern, precaution and proper training of persons involved in the operation, transport, maintenance and storage of equipment.

### Be Aware of Signal Words

A Signal word designates a degree or level of hazard seriousness. The signal words are:  
Indicates an imminently hazardous situation which, if not avoided, will result in death or serious injury. This signal word is limited to the most extreme situations, typically for machine components that, for functional purposes, cannot be guarded.

# ROTARY CUTTER

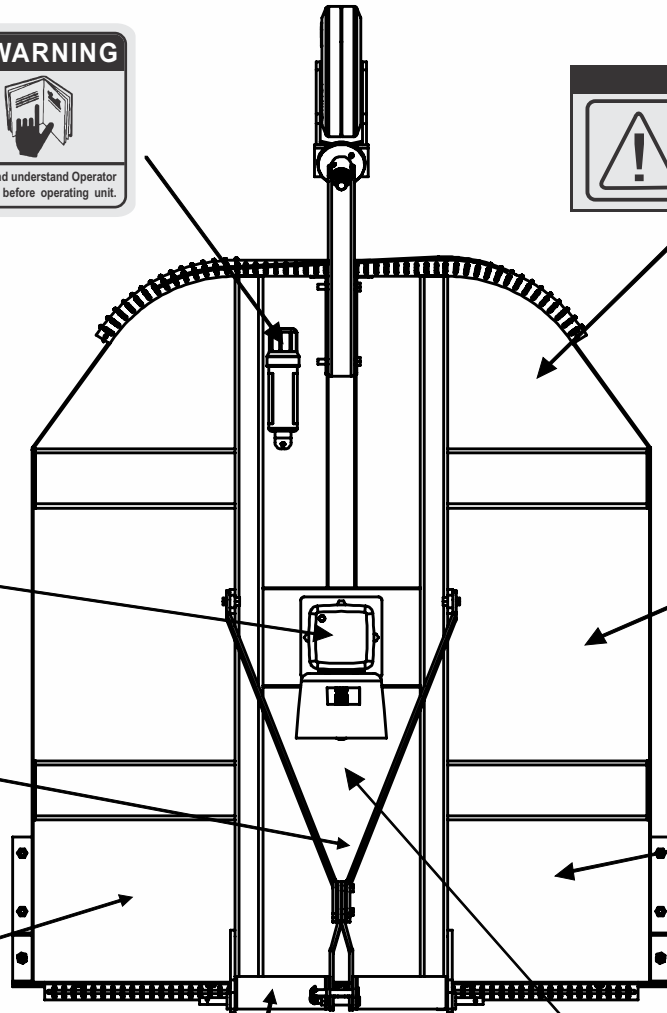
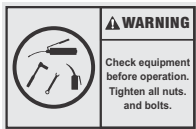
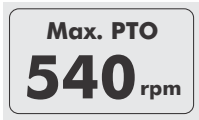

Mfg./Batch details sticker

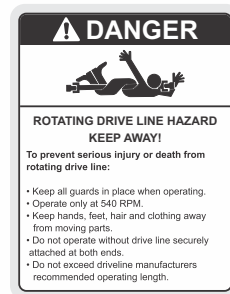

### 3. MAINTANCE & LUBRICATION

To carry out maintenance on this machine follow the safety recommendation listed in this manual.

1. Engage park brake, disengage PTO, shut off tractor and remove key before proceeding with any of the following maintenance.
2. Be sure that the area where the maintenance is to be carried out is dry, clean and level.
3. Suitable safety stands are always to be used if the cutter is required to be raised. Never rely on the tractor hydraulics when working beneath the cutter.
4. Correct servicing and adjustment is the key to the long life of any farm implement. With careful and systematic inspection you can avoid costly downtime, maintenance and repairs.

#### 3.1 MAINTENANCE INSTRUCTIONS

##### Pre-Operating Checks

1. Check all bolts are tight, pins and clips are in the correct position.
2. Check Power Take Off (PTO) shaft is connected correctly.
3. Check for oil leaks from the gearbox, above and below the cutter body.
4. Clear any foreign material from the cutter bar and check for oil leaks from the bottom seal of the gearbox.
5. Check the blades and blade bushes for wear or damage and replace if necessary. Blade bolts must be screwed tight as possible on the blade bar.
6. Check that blade bar and boss are tight on the gearbox shaft. Check the friction clutch is tight on the gearbox shaft, and the plates are in good order.

##### POWER TAKE-OFF SHAFT

The PTO shaft used is of the normal agricultural type. Spares kits, comprising the spider, needle bearings, circlips, etc., are available from most agricultural dealers.

For correct part numbers, see parts manual for when ordering spare parts.

Some routine maintenance is needed to ensure a trouble free life for the PTO shaft. For best results follow instructions below.

- Regularly grease PTO shaft sliding tubes.
- Grease both ends of PTO shaft daily.
- Ensure check chains are securely attached and in good condition.
- Check that PTO guard is in good condition and replace if not.
- Check universal joint bearing journals for roughness or slackness - replace if necessary.

##### SLIP CLUTCH

A slip clutch is incorporated in the PTO driveline. It is designed to slip, absorb the shock load, and protect the driveline. Clutch torque setting is factory set. If clutch slips excessively, check friction discs for excessive wear. Discs are 1/8" thick when new. Replace after 1/32" wear. If your slip clutch has a compression spring check length of springs as assembled on clutch. Length should be 1.5/16". If not adjust length of bolt to obtain proper spring length. If additional adjustment is required tighten each bolt 1/2 turn.

Note: DO NOT tighten spring bolts over ½ turn at any adjustment. Excessive tightening can cause clutch to become frozen and not slip which could cause damage to tractor PTO, drivelines or gearbox. Clutches not used for 30 days should be slackened off, run for a second and re-tightened to above settings.

## I. GREASING

The lubrication chart below shows the frequency at which the greasing points should be lubricated:

PTO SHAFT BEARINGS -Weekly  
PTO SHAFT TUBES- Weekly  
CASTOR WHEEL -Weekly  
DO NOT over grease or it could cause overheating and damage to bearing seals.



Greasing location

### Gear box

Vibration of the Gearbox can cause premature failure of the shaft bearings, as well as structural failures. It is important not to operate the machine with the vibrating. As soon as any vibration is felt stop operating the machine and make the checks listed below.

- Stop tractor engine and neutralize PTO drive.
- Check for missing flails. Replace missing flails immediately.
- Check and ensure that all flail attachments are tight. If any flails are missing or loose and have been replaced and tightened, run the rotors and test for vibration. If vibration is still present, check as follows.
- Stop tractor engine and neutralize PTO drive.
- Check gearbox bearings for roughness or signs of slackness.
- Replace bearings which suffer the above symptoms. If vibration persists it is an indication that the shaft is probably bent and must therefore be replaced.

## 3.2 MAINTENANCE & LUBRICATION SCHEDULED

### I. Daily Maintenance

1. Separate and lubricate all PTO shafts as per PTO lubrication info.
2. Grease all universal joints on all PTO shafts



3. Check the level of the 80W-90 gear oil in the gearbox at the level plug and top up if necessary.



4. Check underside of cutter body and report damage or damaged parts.
5. Check blades for visible signs of damage or excessive wear and service or repair.

6. Ensure blade beam and gearbox hub are tight on the gearbox output shaft and tighten if required.
7. Clear any foreign material from cutter on top and below the deck and check all gearbox seals for leaking oil.



## ii. 40hr Maintenance

1. Check over entire unit for any damaged, worn or fatigued parts and report, repair or replace as necessary.
2. Check universal joints for any excessive wear.
3. If a roller is fitted, check for any play in the bearings and service if necessary. If wheels are fitted, check for play in bearings, and service if necessary. Check the tyre pressure (approx 22 P.S.I) and check the rim and tyre for wear and damage.
4. Check for play in the castor bushes, replace if necessary.
5. Replace danger/safety Symbols if deteriorated.



## iii. 300hr Maintenance

1. Complete full service as per 8 hour and 40 hour procedures.
2. Dismantle friction clutch and inspect the friction discs for wear, distortion or damage. Clutch faces may be polished by loosening the clutch springs and engaging the PTO at low revs to allow the clutch to spin. Do not allow the clutch to overheat. Stop the tractor and remove the key. Reset the clutch by compressing the springs completely then backing the nuts off 2 1/2 turns.

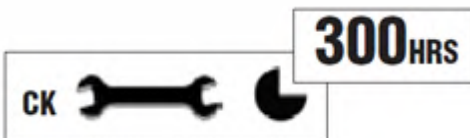

### i. Weekly Maintenance

1. Check and tighten all nuts and bolts on cutter and replace if faulty.
2. Check safety friction clutch by completely compressing clutch spring and then backing off 2 1/2 turns.

### ii. Initial Operation of Cutter

1. Ensure gearbox have correct amount of 80w-90 gear oil. Check all nuts and bolts are correctly tightened and check clutch settings. Repeat this procedure after two hours.



### iii. Annual Check

Back off the clutch spring bolts yearly. Spin the clutch to remove rust etc. from the plates and retighten the bolts to the manufacturer's specified tension.

### 3.3 STORAGE, REMOVAL & DISPOSAL

Before removing the machine from the tractor a thorough check should be made. Follow instructions below.

- Thoroughly clean all moving parts, particularly the rotors.
- Check that all blades are in place and that they are in good condition.
- Smear all unpainted metal parts with grease and lubricate all grease nipples.
- Make a note of any item that needs replacing so that parts can be ordered.

### STORAGE SAFETY

- Following operation, or when unhooking the mower/CUTTER, stop the tractor, set the brakes, disengage the PTO, shut off the engine and remove the ignition keys.
- Store the unit in an area away from human activity.
- Do not park equipment where it can be exposed to direct contact to livestock for long periods of time. Damage and livestock injury could result.
- Make sure all parked machines are on a hard, level surface and engage all safety devices.

### PARKING AND REMOVAL

In the parking position the machine rests on the skids at both sides. To put the machine in this position the following procedure is necessary.

- Remove the bolt from the height adjusting clevis on the main deck to allow the castor arm to swing up.
- Lower the machine to the ground using the tractor hydraulics.
- Stop tractor engine and disengage PTO drive.
- Slacken lift arm and check chains.
- Remove top link.
- Remove linch pin and rings securing lift arms to mounting pins.
- Remove mounting pins from mounting clevis and lift arms.
- Grease mounting pins.
- Replace linch pins.
- Release tractor end of PTO shaft and pull back along splines.
- Start tractor engine and drive carefully forward.
- Grease spline and tubes of PTO and store with the machine or keep in a safe dry place.

### DISPOSAL

If the machine is out of order, all the parts that may cause danger have to be made inert.

The materials forming the machine have to undergo a differentiated division, these materials are:

- Steel ( Frame, blades etc.)
- Gear oil (within gearbox)
- Plastic (PTO guarding)

All the above mentioned operations and the disposal have to be carried out in total respect of the present provisions of law on the subject.

### 3.4 TROUBLE-SHOOTING CHART

PROBLEM	CAUSES	REMEDIES/SOLUTION
Irregular Cut	<ul style="list-style-type: none"> <li>Worn, bent or broken blades</li> <li>Machine is not level with the ground</li> <li>Material blockage due to speed</li> </ul>	<ul style="list-style-type: none"> <li>Replace it / them</li> <li>Level the machine</li> <li>Reduce working speed</li> </ul>
Machine Noise	<ul style="list-style-type: none"> <li>Loose bolts</li> <li>Cracks or initiation of cracks in frame.</li> </ul>	<ul style="list-style-type: none"> <li>Tighten Bolts</li> <li>Have it repaired in Authorized workshop</li> </ul>
Gearbox noise	<ul style="list-style-type: none"> <li>Lack of oil</li> <li>Worn bearings</li> <li>Worn gears</li> </ul>	<ul style="list-style-type: none"> <li>Fill to level</li> <li>Replace</li> <li>Replace</li> </ul>
Premature blade wear	<ul style="list-style-type: none"> <li>Blades touching the ground</li> </ul>	<ul style="list-style-type: none"> <li>Adjust the height of cut</li> </ul>
Excessive backlash in joints	<ul style="list-style-type: none"> <li>Worn pins</li> </ul>	<ul style="list-style-type: none"> <li>Replace</li> </ul>
Vibration	<ul style="list-style-type: none"> <li>Damaged blades.</li> <li>Damaged beam.</li> <li>Bent spindle.</li> <li>Worn spindle bearings.</li> <li>Twisted PTO Shaft.</li> <li>PTO shaft crosses worn.</li> <li>Lifting too high with PTO engaged</li> <li>Broken or worn blades</li> <li>Unbalanced rotor</li> </ul>	<ul style="list-style-type: none"> <li>Replace.</li> <li>Replace.</li> <li>Replace.</li> <li>Replace.</li> <li>Replace Shaft Section.</li> <li>Replace.</li> <li>Disengage/Reduce Lift.</li> <li>Replace</li> <li>Replace in authorized workshop</li> </ul>
Drive Shaft Failures	<ul style="list-style-type: none"> <li>Inadequate lubrication of sliding members.</li> <li>Incorrect lengths of sliding members.</li> <li>Incorrect clutch setting.</li> <li>Over lifting rotary cutter while drive shaft rotating.</li> <li>Working rotary cutter using tractor foot throttle.</li> </ul>	<ul style="list-style-type: none"> <li>Clean and lubricate as per maintenance schedule.</li> <li>Shorten or replace as required.</li> <li>Adjust correctly.</li> <li>Allow PTO drive to stop prior to high lifts.</li> <li>Work all implements with hand throttle and select gear to give required travel speed.</li> <li>(Use foot throttle only for road transport.)</li> </ul>
Clutch Overheating	<ul style="list-style-type: none"> <li>Incorrect setting.</li> <li>Friction discs worn.</li> <li>Machine overworked</li> </ul>	<ul style="list-style-type: none"> <li>Reset.</li> <li>Replace.</li> <li>Reduce work rate or use a smaller tractor.</li> </ul>
Gearbox Leaking Oil	<ul style="list-style-type: none"> <li>Damaged seals or gaskets.</li> <li>Bent output spindle.</li> </ul>	<ul style="list-style-type: none"> <li>Replace seals/gaskets.</li> <li>Replace spindle.</li> </ul>
Blade Wedges Blade Bolts Wearing	<ul style="list-style-type: none"> <li>Low operating RPM.</li> <li>Journals worn.</li> <li>Blade bolts not tight.</li> </ul>	<ul style="list-style-type: none"> <li>Increase PTO to 540 rpm.</li> <li>Replace journals, bolts and nuts.</li> <li>Tighten.</li> </ul>
Excessive Blade Wear	<ul style="list-style-type: none"> <li>Excessive blade speed.</li> <li>Cutting height too low.</li> <li>Sandy or stony conditions.</li> </ul>	<ul style="list-style-type: none"> <li>Check PTO rpm is 540 rpm max.</li> <li>Raise cutting height.</li> <li>Accept wear or raise cutting height.</li> </ul>
Scalping	<ul style="list-style-type: none"> <li>Cutting height too low.</li> <li>Linkage pins worn.</li> </ul>	<ul style="list-style-type: none"> <li>Raise cutting height.</li> <li>Replace.</li> </ul>
Excessive Skid Damage to Turf &/or Skid Wear	<ul style="list-style-type: none"> <li>Too much reliance on skids for support of CUTTER.</li> <li>Linkage pins worn.</li> </ul>	<ul style="list-style-type: none"> <li>Increase support of ROTARY CUTTER on the tractor linkage; fit a rear height control wheel or rollers.</li> <li>Replace.</li> </ul>

## 4. PICTURE & PART CATALOGUE

### CUTTER BAR ASSEMBLY PART LIST

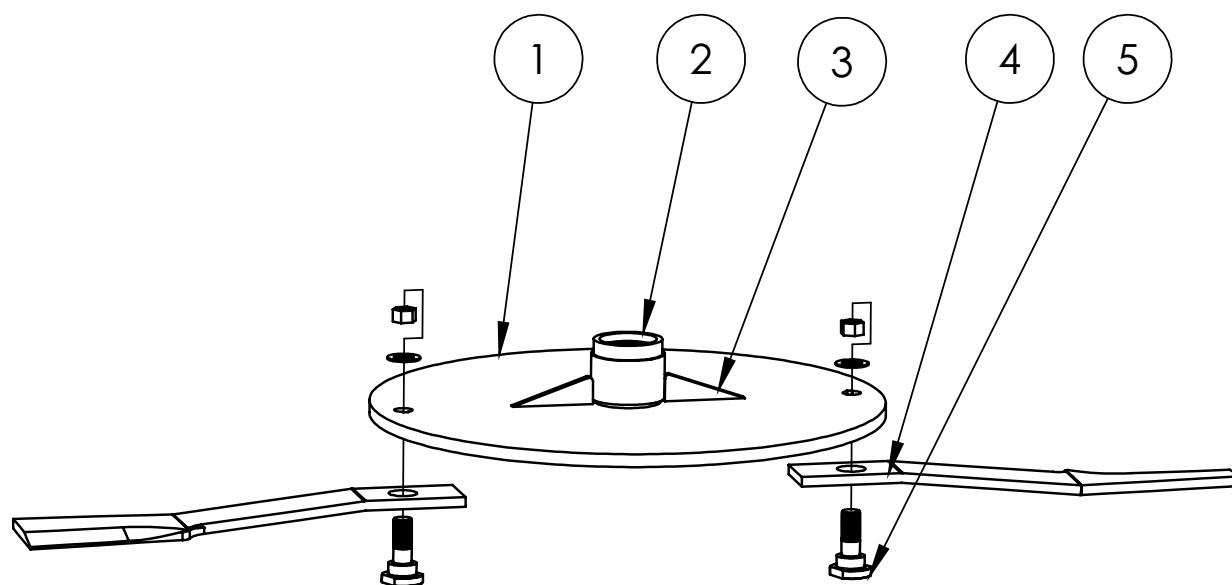

### CUTTER BAR ASSEMBLY PART LIST

SR.NO.	PART NAME	PART NUMBER				QTY
		81030021(4 FT)	81030020(5 FT)	81030022(6 FT)	81030023(7 FT)	
1	ROUND PAN	79440009	79440004		79440008	1
2	SPLINE HUB	10070198	10090038			1
3	RIB	79440010				2
4	BLADE	79440001	78210006	78210004	78210008	2
5	BLADE BOLT	78210005				2

**STANDARD DUTY ROTARY CUTTER (4 FEET)**

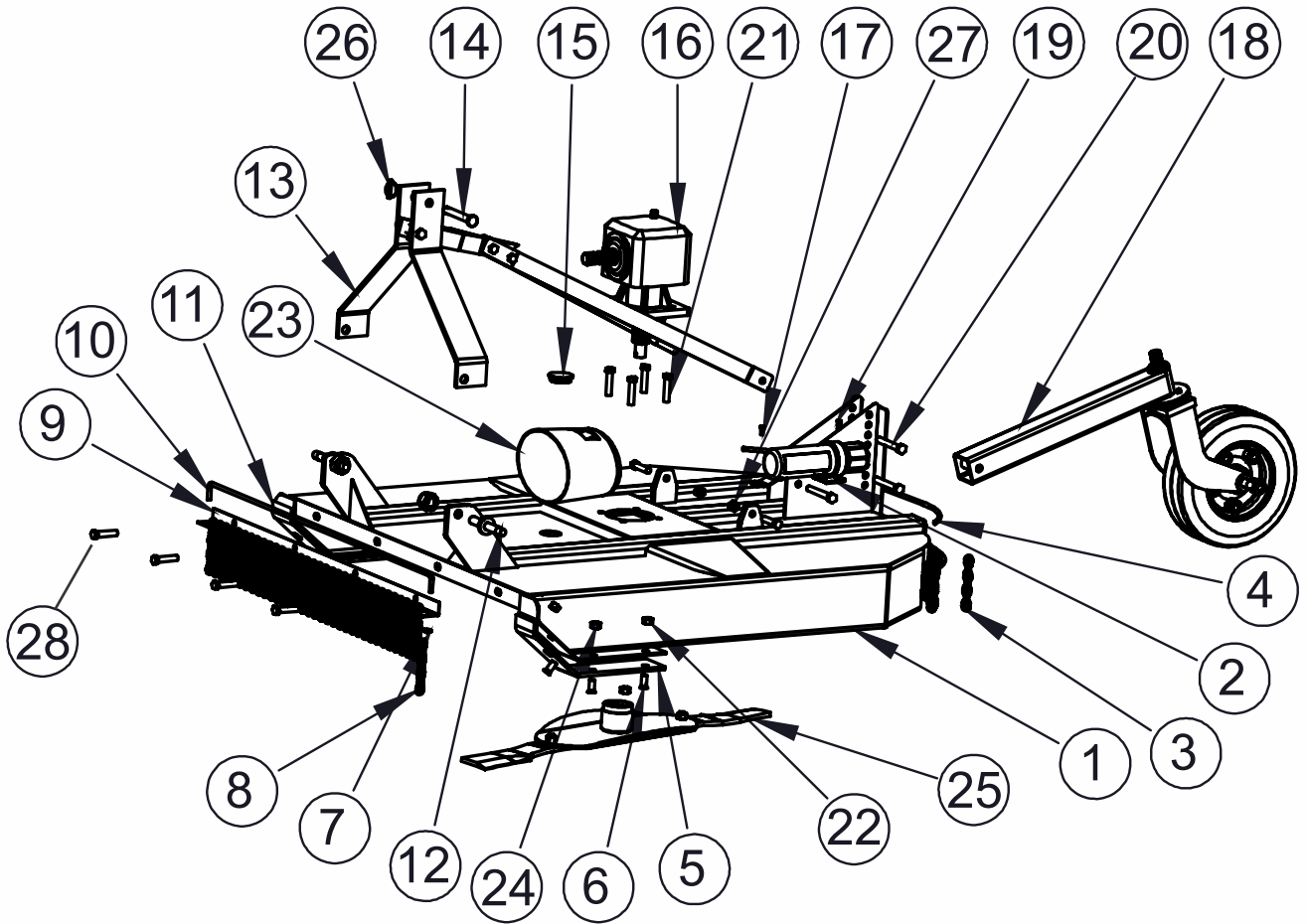

**STANDARD DUTY ROTARY CUTTER (4 FEET)**

SR.NO.	PART NAME	PART NO.	QUANTITY
		<b>81030021(4 FT)</b>	<b>81030021(4 FT)</b>
1	FRAME ASSEMBLY	74370169	1
2	CANISTER-2 INCH X12.5 INCH	80060050	1
3	REAR CHAIN LINK 8 MM	79430030	18
4	WIRE ROPE REAR SIDE	79430018	1
5	DEPTH SKID FLAT RIGHT	74370168	1
6	CSK BOLT M16X40MM	10260039	6
7	WIRE ROPE END CLAMPS	60050579	4
8	FRONT CHAIN LINKS 8MM	79430016	20
9	FRONT CHAIN LINK PLATE	74370171	1
10	WIRE ROPE FRONT SIDE	79430017	1
11	DEPTH SKID FLAT LEFT	74370167	1
12	HITCH PIN 30X148 (CAT1)	10020237	2
13	THREE POINT LINKAGE ASSEMBLY	74750027	1
14	PIN 19X110 MM	10020317	1
15	SAFETY CAP GROMMET	20052037	1
16	GEAR BOX ASSEMBLY	10490026	1
17	HEX HEAD BOLT M8X25X1.25MM	10260360	4
18	DEPTH WHEEL ASSEMBLY	79430013	1
19	NYLOCK NUT M8X1.25MM	10280027	4
20	HEX HEAD BOLT M16X125X2MM	10260023	4
21	HEX HEAD BOLT M16X75X2MM	10260018	8
22	NYLOCK NUT M16X2MM	10280005	22
23	SAFETY COVER	10150025	1
24	SPRING WASHER 16MM	10270005	22
25	CUTTER BAR ASSEMBLY	79440005	1
26	LINCH PIN 10MM	10020022	1
27	SPRING WASHER M8 MM	10270001	4
28	HEX HEAD BOLT M16X40	10260077	4

**MEDIUM DUTY ROTARY CUTTER (5 & 6 FEET)**

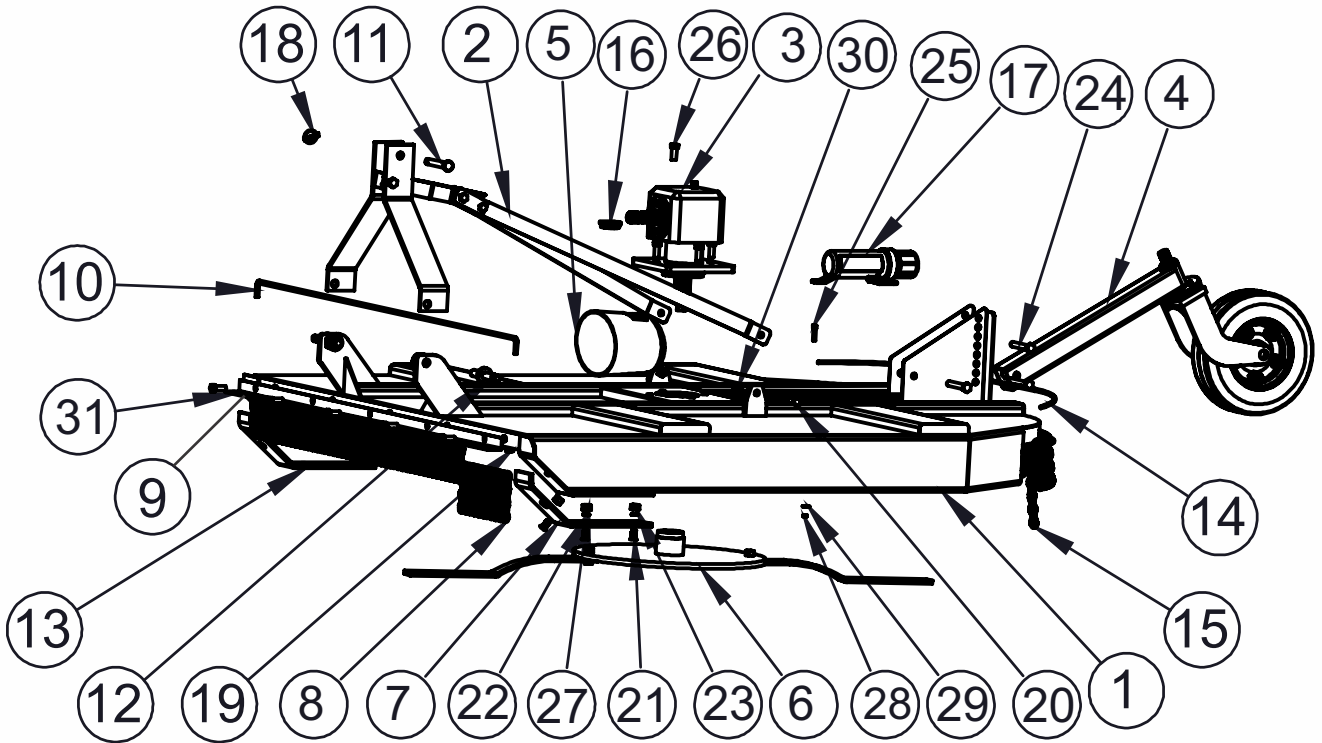

**MEDIUM DUTY ROTARY CUTTER (5 & 6 FEET)**

SR.NO.	PART NAME	PART NO.		QUANTITY	
		81030020(5 FT)	81030022(6 FT)	81030020(5 FT)	81030022(6 FT)
1	FRAME ASSEMBLY	74370146	74370170	1	
2	THREE POINT LINKAGE ASSEMBLY	74750021		1	
3	GEAR BOX ASSEMBLY	71580001		1	
4	DEPTH WHEEL ASSEMBLY	79430013		1	
5	SAFETY COVER	10150025		1	
6	CUTTER BAR ASSEMBLY	79440003	79440006	1	
7	DEPTH SKID FLAT RIGHT	74370168		1	
8	FRONT CHAIN LINKS 8MM	79430016		25	30
9	FRONT CHAIN LINK PLATE	74370165	74370173	1	
10	WIRE ROPE FRONT SIDE	79430014	79430019	1	
11	PIN 19X110 MM	10020317		1	
12	HITCH PIN 30X148 (CAT1)	10020237		2	
13	DEPTH SKID FLAT LEFT	74370167		1	
14	WIRE ROPE REAR SIDE	79430015	79430020	1	
15	REAR CHAIN LINK 8 MM	79430030		21	25
16	SAFETY CAP GROMMET	20052037		1	
17	CANISTER-2 INCH X12.5 INCH	80060050		1	
18	LINCH PIN 10MM	10020022		1	
19	WIRE ROPE END CLAMPS	60050579		4	
20	HEX HEAD BOLT M16X75X2MM	10260018		4	
21	CSK BOLT M16X40MM	10260039		6	
22	SPRING WASHER 16MM	10270005		18	
23	NYLOCK NUT M16X2MM	10280005		18	
24	HEX HEAD BOLT M16X125X2MM	10260023		4	
25	HEX HEAD BOLT M8X25X1.25MM	10260360		4	
26	HEX HEAD BOLT M18X75X2.5	10260085		4	
27	NYLOCK NUT M18X2.5MM	10280020		4	
28	NYLOCK NUT M8X1.25MM	10280027		4	
29	SPRING WASHER M8 MM	10270001		4	
30	SPRING WASHER 18MM	10270006		4	
31	HEX HEAD BOLT M16X40	10260077		4	

**HEAVY DUTY ROTARY CUTTER (7 FEET)**

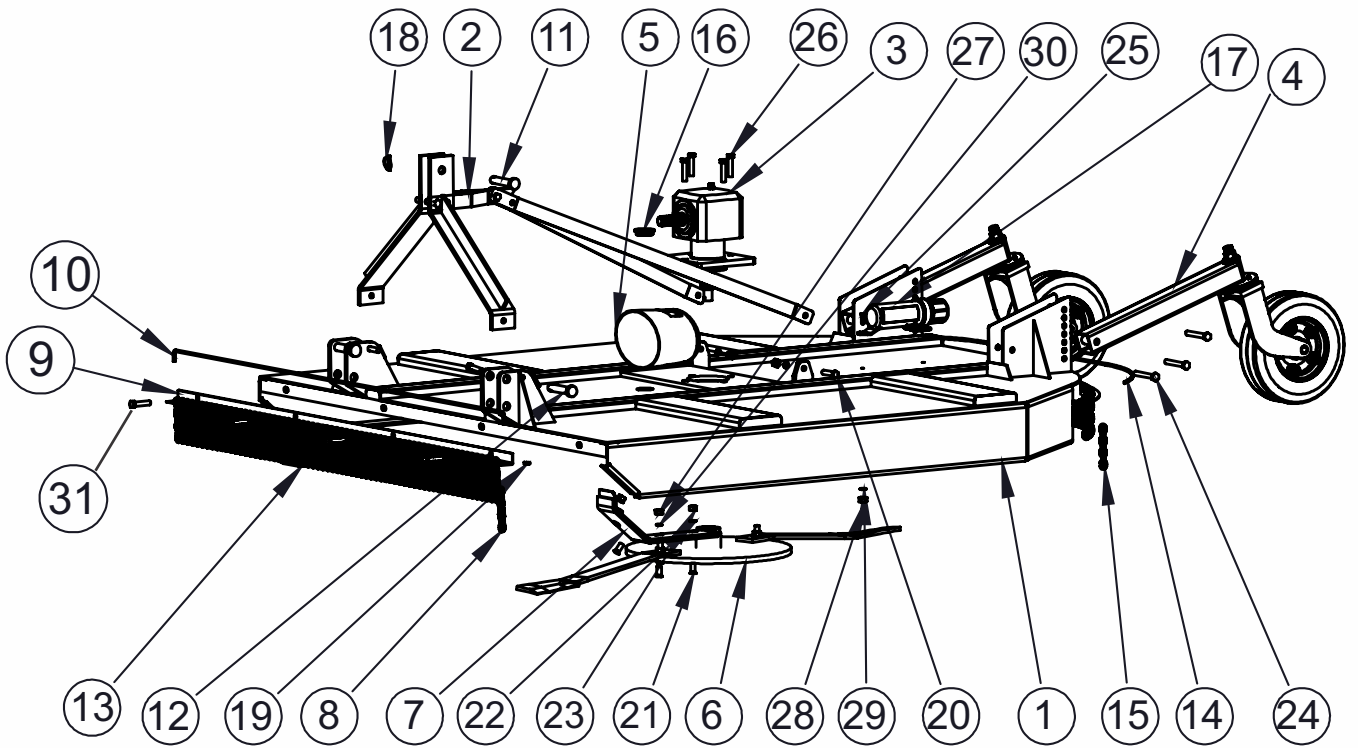



## HEAVY DUTY ROTARY CUTTER (7 FEET)

SR.NO.	PART NAME	PART NO.	QUANTITY
		<b>81030023 (7 FT)</b>	<b>81030023 (7 FT)</b>
1	FRAME ASSEMBLY	74370175	1
2	THREE POINT LINKAGE ASSEMBLY	74750029	1
3	GEAR BOX ASSEMBLY	71580001	1
4	DEPTH WHEEL ASSEMBLY	79430013	1
5	SAFETY COVER	10150025	1
6	CUTTER BAR ASSEMBLY	79440007	1
7	DEPTH SKID FLAT RIGHT	74370178	1
8	FRONT CHAIN LINKS 8MM	79430016	34
9	FRONT CHAIN LINK PLATE	74370176	1
10	WIRE ROPE FRONT SIDE	79430021	1
11	PIN 25X130MM	10020036	1
12	PIN 28X155MM	10020134	2
13	DEPTH SKID FLAT LEFT	74370179	1
14	WIRE ROPE REAR SIDE	79430022	1
15	REAR CHAIN LINK 8 MM	79430030	33
16	SAFETY CAP GROMMET	20052037	1
17	CANISTER-2 INCH X12.5 INCH	80060050	1
18	LINCH PIN 10MM	10020022	3
19	WIRE ROPE END CLAMPS	60050579	4
20	HEX HEAD BOLT M16X75X2MM	10260018	6
21	CSK BOLT M16X40MM	10260039	6
22	SPRING WASHER 16MM	10270005	23
23	NYLOCK NUT M16X2MM	10280005	23
24	HEX HEAD BOLT M16X125X2MM	10260023	7
25	HEX HEAD BOLT M8X25X1.25MM	10260360	4
26	HEX HEAD BOLT M18X75X2.5	10260085	4
27	NYLOCK NUT M18X2.5MM	10280020	4
28	NYLOCK NUT M8X1.25MM	10280027	4
29	SPRING WASHER M8 MM	10270001	4
30	SPRING WASHER 18MM	10270006	4
31	HEX HEAD BOLT M16X40	10260077	4

**ROTARY CUTTER REPLACEABLE PART**

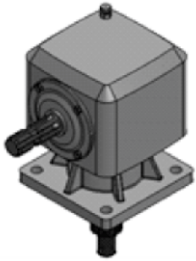

(1)

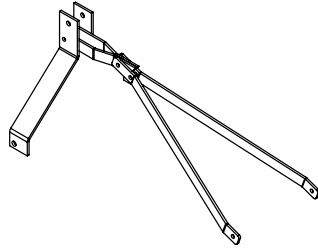

(2)

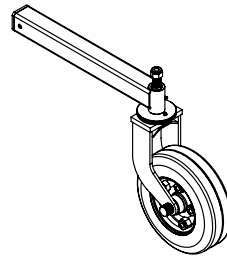

(3)



(4)



(5)



(6)



(7)

SR.NO.	PART NAME	PART NO.			
		4 FT(81030021)	5 FT(81030020)	6 FT(81030022)	7 FT(81030023)
1	GEAR BOX	10490026	71580001		
2	THREE POINT LINKAGE ASSEMBLY	74750027	74750021	74750029	
3	DEPTH WHEEL ASSEMBLY	79430013			
4	BLADE	79440001	78210006	78210004	78210008
5	DEPTH SKID LEFT SIDE	74370167			74370179
6	DEPTH SKID RIGHT SIDE	74370168			74370178
7	BLADE BOLT	78210005			

**TYRE ASSEMBLY**

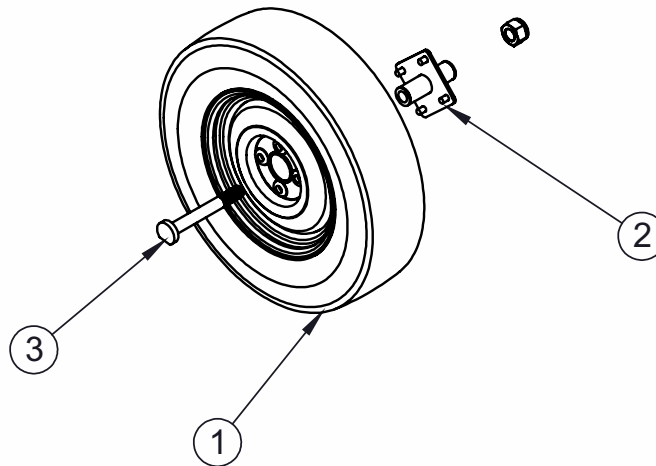

SR.NO.	PART NO.	PART NAME	QTY
1	LAMINATED TYRE WHEEL WITH RIM	11030052	1
2	FBRICATED HUB SET	10090092	1
3	TYRE AXLE PIN SET LAMINATED TYRE	10020351	1

**DEPTH WHEEL ASSEMBLY**

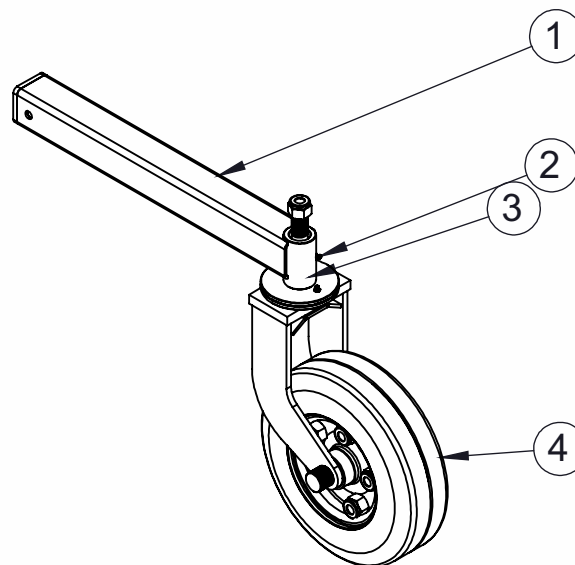

SR.NO.	DESCRIPTION	PART NO.	QTY
1	DEPTH WHEEL PIPE ASSEMBLY	79430027	1
2	GREASE NIPPLE	10300095	2
3	FORK ASSEMBLY	79430028	1
4	TYRE ASSEMBLY	79430029	1

## DELIVERY CHECKLIST

<b>Dealer Pre-Delivery (Please Tick)</b>
<p><b>1. Dealer Pre-Delivery Checklist</b></p> <ol style="list-style-type: none"> <li>1. The customer or person responsible has been given the operator's manual.</li> <li>2. The customer undertakes to read the complete operator's manual and understands all aspects of the manual before operation of the machine.</li> <li>3. All safety, operational and maintenance information have been explained and demonstrated.</li> <li>4. All greasing and oil points, stickers, guarding and ID plate have been identified and physically pointed out.</li> <li>5. The customer agrees that it is his responsibility to read and carry out the safety, maintenance and operation as per this operator's manual.</li> </ol>

<b>Customer Delivery (Please Tick)</b>
<p><b>2. Customer Delivery Checklist</b></p> <ol style="list-style-type: none"> <li>1. The customer or person responsible has been given the operator's manual.</li> <li>2. The customer undertakes to read the complete operator's manual and understands all aspects of the manual before operation of the machine.</li> <li>3. All safety, operational and maintenance information have been explained and demonstrated.</li> <li>4. All greasing and oil points, stickers, guarding and ID plate have been identified and physically pointed out.</li> <li>5. The customer agrees that it is his responsibility to read and carry out the safety, maintenance and operation as per this operator's manual.</li> </ol>

<b>Please Complete all Dealer information Below</b>
<p><b>Dealer Information</b></p> <p>Dealer's Name.....</p> <p>Address..... .....</p> <p>State..... Postcode.....</p> <p>Phone..... Fax.....</p> <p>Email.....</p> <p>Service Person.....</p> <p>I confirm that the pre-delivery service was performed on this machine.</p> <p>Signature.....</p> <p>Date.....</p> <p>Comments..... ..... .....</p>

<b>Please Complete all Customer Information Below</b>
<p><b>Customer Information</b></p> <p>Customer's Name.....</p> <p>Address..... .....</p> <p>State..... Postcode.....</p> <p>Phone..... Fax.....</p> <p>Email.....</p> <p>Delivery Person.....</p> <p>I confirm that all of the delivery checks were explained and performed.</p> <p>Signature.....</p> <p>Delivery Date.....</p> <p>Comments..... ..... .....</p>



**WARRANTY CARD**  
**Customer Copy**

CUSTOMER NAME Mr./ Mrs :

ADDRESS :

MOBILE NO. :

Email :

NAME OF IMPLEMENT :

MODEL NO. :

YEAR OF Mfg. :

SERIAL NO. :

REGISTRATION NO. :

DATE OF PURCHASING :

NAME OF DEALER :

Customer`s Signature

Dealer`s Signature

**FIELDKING USA, INC.**

960 Holmdel Road Suite 2-02, Holmdel, NJ 07733, USA

✉ usa@fieldking.com, 🌐 www.fieldkingusa.com





**WARRANTY CARD**  
Company Copy

CUSTOMER NAME Mr./ Mrs :

ADDRESS :

MOBILE NO. :

Email :

NAME OF IMPLEMENT :

MODEL NO. :

YEAR OF Mfg. :

SERIAL NO. :

REGISTRATION NO. :

DATE OF PURCHASING :

NAME OF DEALER :

Customer`s Signature

Dealer`s Signature

**FIELDKING USA, INC.**

960 Holmdel Road Suite 2-02, Holmdel, NJ 07733, USA

✉ usa@fieldking.com, 🌐 www.fieldkingusa.com







**WARRANTY CARD**  
Dealer Copy

CUSTOMER NAME Mr./ Mrs :

ADDRESS :

MOBILE NO. :

Email :

NAME OF IMPLEMENT :

MODEL NO. :

YEAR OF Mfg. :

SERIAL NO. :

REGISTRATION NO. :

DATE OF PURCHASING :

NAME OF DEALER :

Customer`s Signature

Dealer`s Signature

**FIELDKING USA, INC.**

960 Holmdel Road Suite 2-02, Holmdel, NJ 07733, USA

✉ usa@fieldking.com, 🌐 www.fieldkingusa.com



Tillage



Cultivation



Landscaping



Seeding & Plantation



Harvest



Post Harvest

*Solutions...*



22-08-2020

## FIELDKING USA, INC.

960 Holmdel Road Suite 2-02, Holmdel, NJ 07733, USA

✉ [usa@fieldking.com](mailto:usa@fieldking.com), [www.fieldkingusa.com](http://www.fieldkingusa.com)